

# AUSTIN TRAVIS COUNTY EMS D-4500 METROMEDIC

DEALER SIGNATURE 

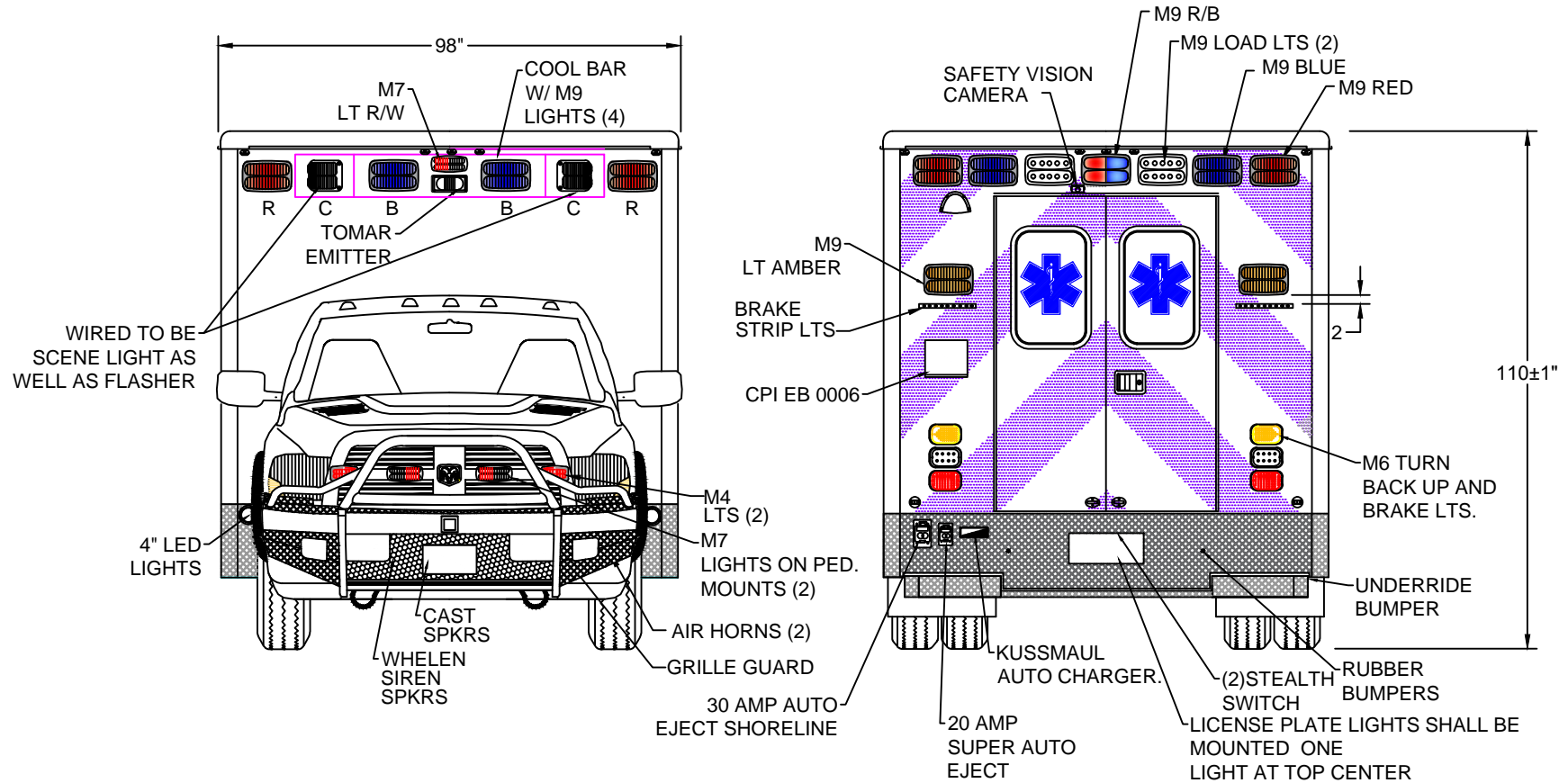



DOOR NO.	INTERIOR DIMENSIONS			NOTES	DOOR NO.	DOOR JAM OPENING		MISC. NOTES	PROPRIETARY AND CONFIDENTIAL THIS INFORMATION CONTAINED IN THIS DRAWING IS THE SOLE PROPERTY OF ROAD RESCUE ANY REPRODUCTION IN PART OR AS A WHOLE WITHOUT THE WRITTEN PERMISSION OF ROAD RESCUE IS PROHIBITED.
	HEIGHT	WIDTH	DEPTH			HEIGHT	WIDTH		
DETAILS ARE CONCEPTUAL ONLY. LAYOUT AND ALL DIMENSIONS ARE APPROXIMATE AND SUBJECT TO MODIFICATION BY DESIGN ENGINEERING.									

**Road Rescue** 2737 N. FORSYTH ROAD  
WINTER PARK, FL 32792  
www.roadrescue.com PHONE 800-932-7077 FAX 800-513-2688

## FRONT REAR EXTERIOR DETAIL

BID NUMBER

DRAWN BY: SG DATE: 06/01/17 REVISION 1: REVISION 2: REVISION 3: SCALE: SHEET 1 / 9

 CA142814 

NOTE: THIS DRAWING IS SUBJECT TO CHANGE PENDING ROAD RESCUE PRODUCTION ENGINEERING APPROVAL. © ROAD RESCUE ALL RIGHTS RESERVED.



# AUSTIN TRAVIS COUNTY EMS D-4500 METROMEDIC

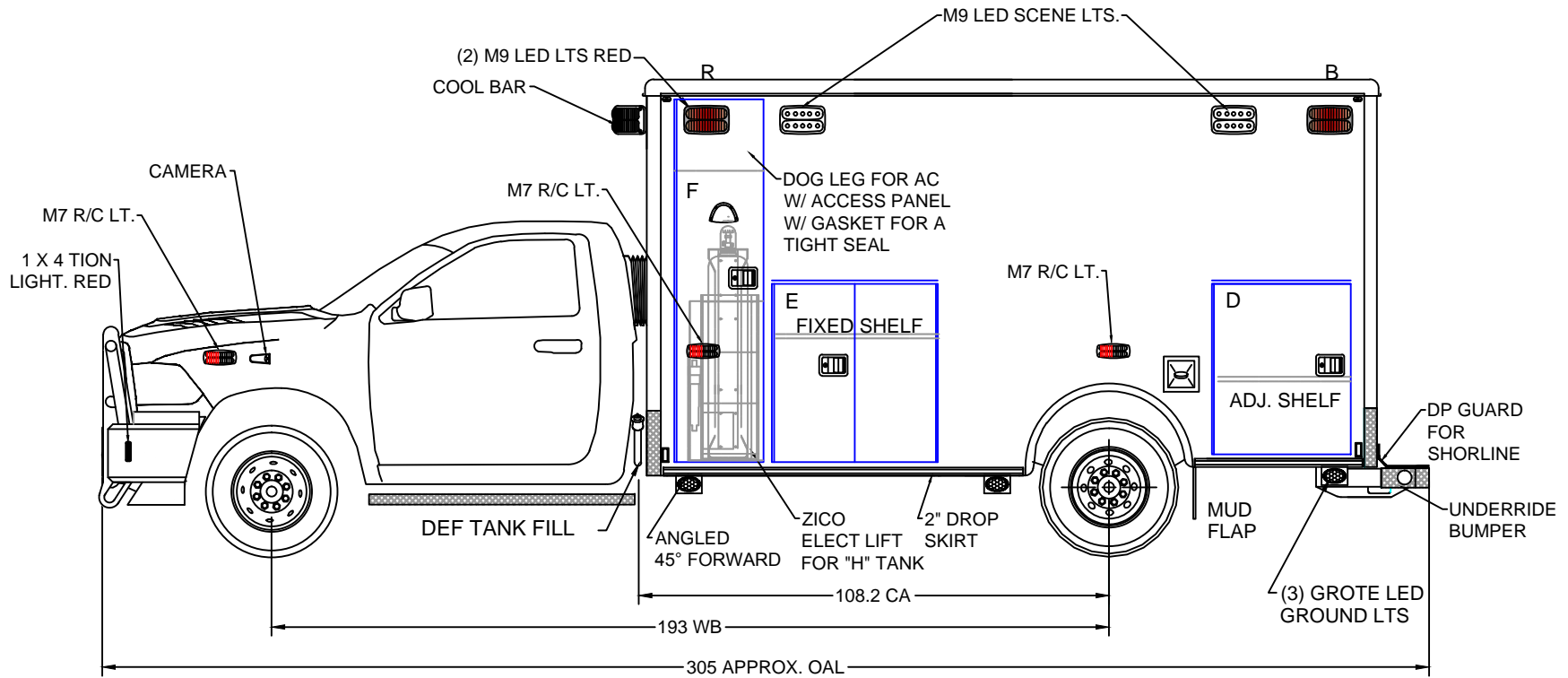

ALL WARNING LTS. HAVE CLR. LENSES

DETAILS ARE CONCEPTUAL ONLY. LAYOUT AND ALL DIMENSIONS ARE APPROXIMATE AND SUBJECT TO MODIFICATION BY DESIGN ENGINEERING.

DOOR NO.	INTERIOR DIMENSIONS			DOOR NO.	DOOR JAM OPENING			MISC. NOTES	PROPRIETARY AND CONFIDENTIAL THIS INFORMATION CONTAINED IN THIS DRAWING IS THE SOLE PROPERTY OF ROAD RESCUE ANY REPRODUCTION IN PART OR AS A WHOLE WITHOUT THE WRITTEN PERMISSION OF ROAD RESCUE IS PROHIBITED.
	HEIGHT	WIDTH	DEPTH		HEIGHT	WIDTH	DEPTH		
D	39.25	34.00	18.00	D	36.25	30.50			
E	40.25	38.75	19.00	E	38.25	36.50			
F	67.375	23.25	19.00	F	83.75	20.25			

**Road Rescue** 2737 N. FORSYTH ROAD  
WINTER PARK, FL 32792

## LEFT EXTERIOR DETAIL

BID NUMBER

www.roadrescue.com PHONE 800-932-7077 FAX 800-513-2688

DRAWN BY SG DATE 06/01/17 REVISION 1

REVISION 2

REVISION 3

SCALE

SHEET 2 / 9

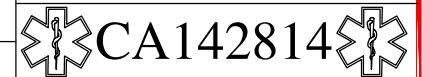

NOTE: THIS DRAWING IS SUBJECT TO CHANGE PENDING ROAD RESCUE PRODUCTION ENGINEERING APPROVAL. © ROAD RESCUE ALL RIGHTS RESERVED.

# AUSTIN TRAVIS COUNTY EMS D-4500 METROMEDIC

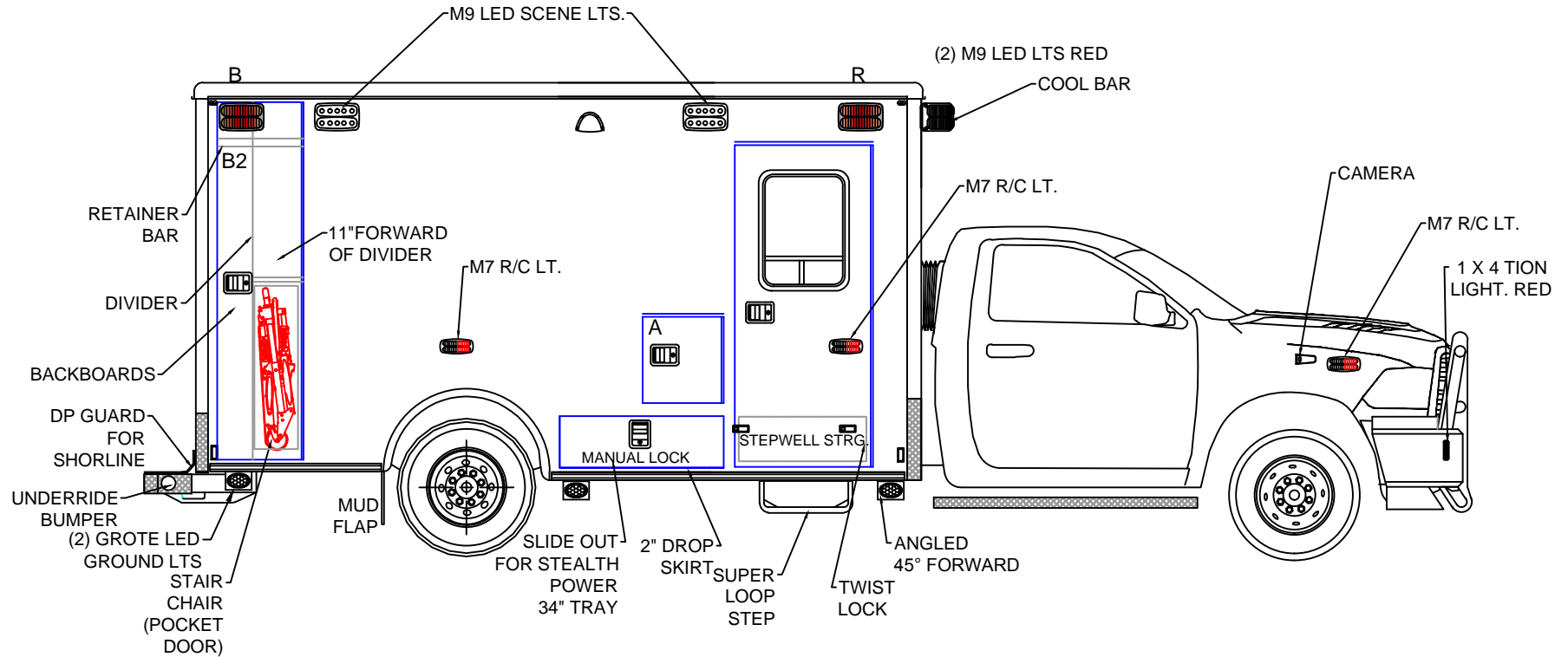

ALL WARNING LTS. HAVE CLR. LENSES

DETAILS ARE CONCEPTUAL ONLY.  
LAYOUT AND ALL DIMENSIONS ARE APPROXIMATE AND  
SUBJECT TO MODIFICATION BY DESIGN ENGINEERING.

DOOR NO.	INTERIOR DIMENSIONS			DOOR NO.	DOOR JAM OPENING			MISC. NOTES	PROPRIETARY AND CONFIDENTIAL THIS INFORMATION CONTAINED IN THIS DRAWING IS THE SOLE PROPERTY OF ROAD RESCUE ANY REPRODUCTION IN PART OR AS A WHOLE WITHOUT THE WRITTEN PERMISSION OF ROAD RESCUE IS PROHIBITED.
	HEIGHT	WIDTH	DEPTH		HEIGHT	WIDTH	DEPTH		
A	20.00	22.00	21.75	A	19.50	20.75			
BATT	13.00	40.25	19.125	BATT	11.875	38.00			
B2	85.00	20.00	20.375	B2	81.75	19.25			

**Road Rescue** 2737 N. FORSYTH ROAD  
WINTER PARK, FL 32792

www.roadrescue.com PHONE 800-932-7077 FAX 800-513-2688



DRAWN BY SG DATE 06/01/17 REVISION 1

## RIGHT EXTERIOR DETAIL

REVISION 2 REVISION 3 SCALE

SHEET 3 / 9

BID NUMBER

 CA142814 

NOTE: THIS DRAWING IS SUBJECT TO CHANGE PENDING ROAD RESCUE PRODUCTION ENGINEERING APPROVAL. © ROAD RESCUE ALL RIGHTS RESERVED.



# AUSTIN TRAVIS COUNTY EMS D-4500 METROMEDIC

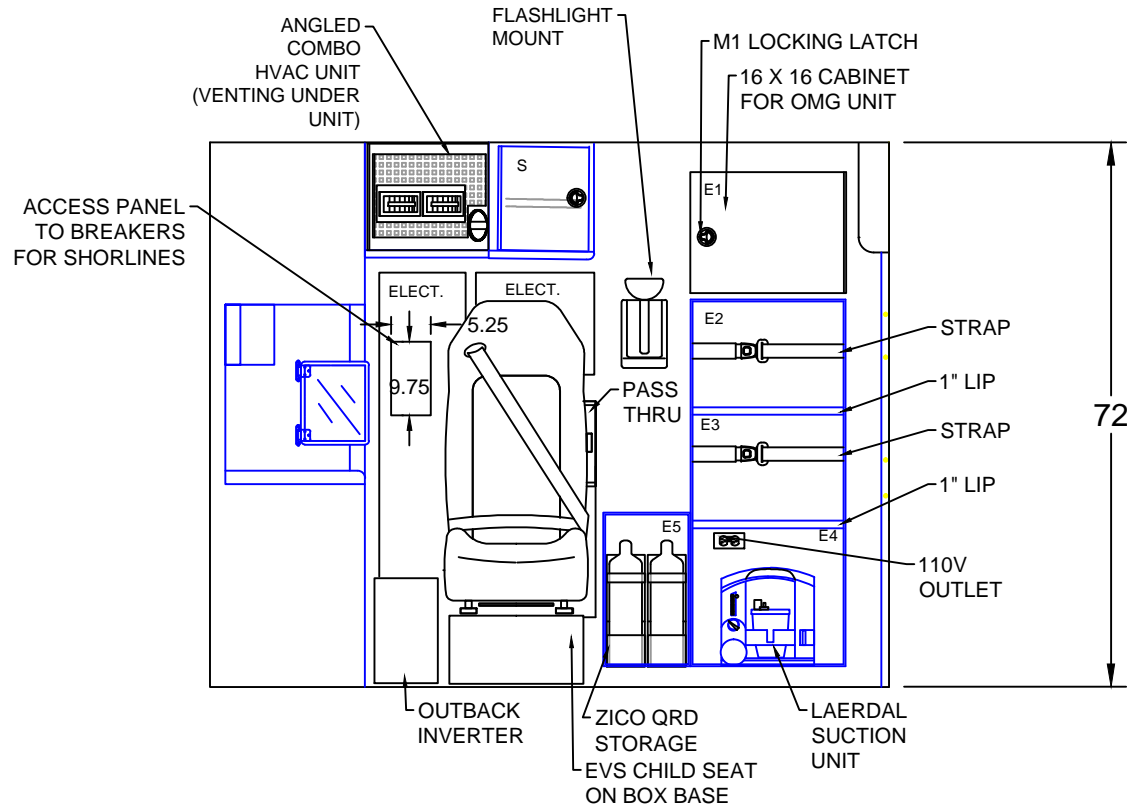

DOOR NO.	CABINET DIMENSIONS			MISC. NOTES	DOOR NO.	CABINET DIMENSIONS			NOTES:	PROPRIETARY AND CONFIDENTIAL THIS INFORMATION CONTAINED IN THIS DRAWING IS THE SOLE PROPERTY OF ROAD RESCUE ANY REPRODUCTION IN PART OR AS A WHOLE WITHOUT THE WRITTEN PERMISSION OF ROAD RESCUE IS PROHIBITED.
	HEIGHT	WIDTH	DEPTH			HEIGHT	WIDTH	DEPTH		
E1	17.50	24.00	5.25	STORAGE FOR OMG W/ LOCK	E5	21.00	12.00	7.00	DETAILS ARE CONCEPTUAL ONLY. LAYOUT AND ALL DIMENSIONS ARE APPROXIMATE AND SUBJECT TO MODIFICATION BY DESIGN ENGINEERING.	
E2	16.00	24.00	7.25		S	12.00	12.00	12.00		
E3	17.00	24.00	7.25							
E4	19.00	24.00	7.25							

**Road Rescue** 2737 N. FORSYTH ROAD  
WINTER PARK, FL 32792  
www.roadrescue.com PHONE 800-932-7077 FAX 800-513-2688

## FRONT INTERIOR DETAIL

BID NUMBER  
**CA142814**

DRAWN BY: SG DATE: 06/01/17 REVISION 1: REVISION 2: REVISION 3: SCALE: SHEET 4 / 9

NOTE: THIS DRAWING IS SUBJECT TO CHANGE PENDING ROAD RESCUE PRODUCTION ENGINEERING APPROVAL. © ROAD RESCUE ALL RIGHTS RESERVED.



# AUSTIN TRAVIS COUNTY EMS D-4500 METROMEDIC

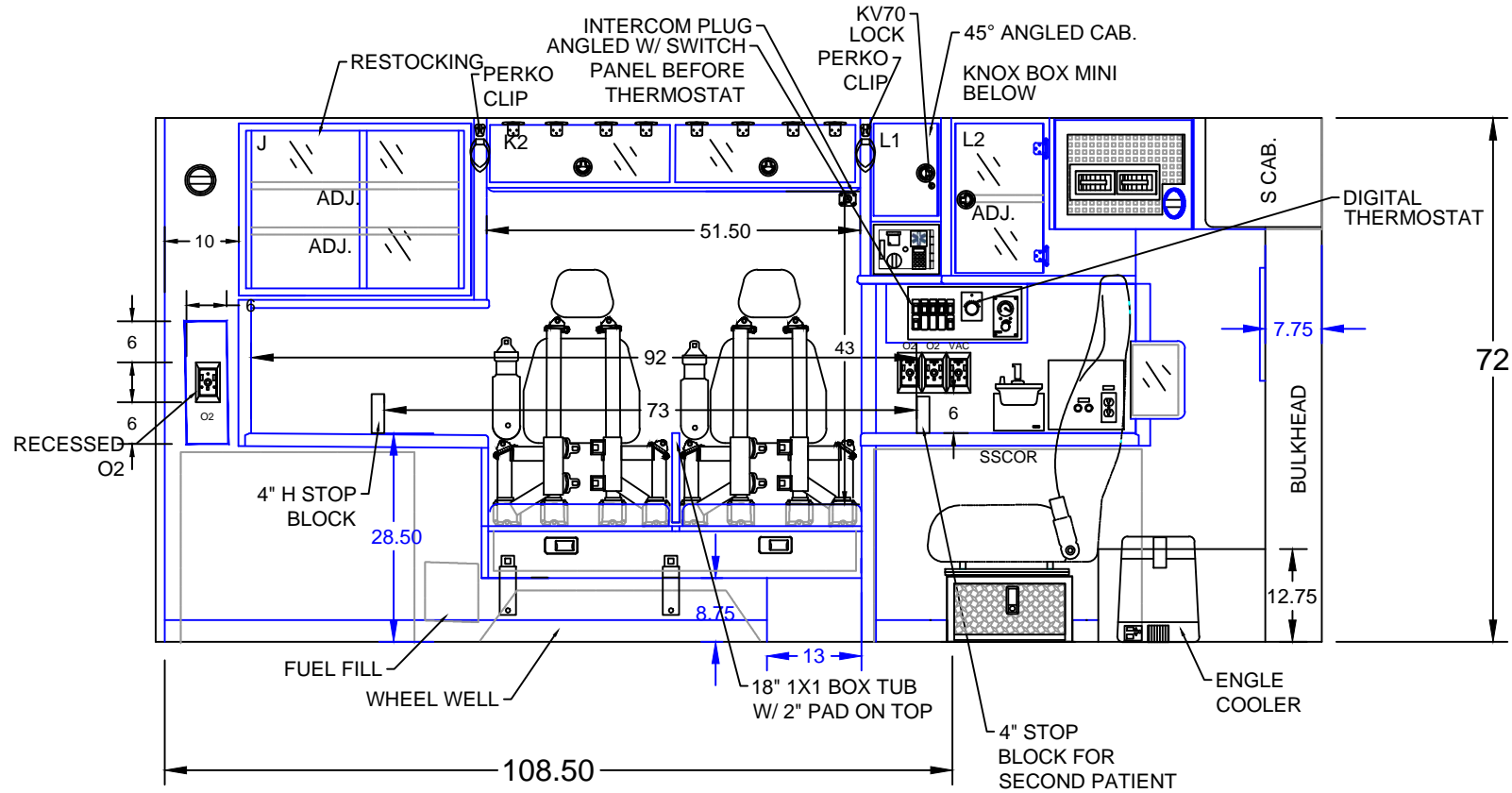

DOOR NO.	CABINET DIMENSIONS			DOOR NO.	CABINET DIMENSIONS			NOTES:  DETAILS ARE CONCEPTUAL ONLY. LAYOUT AND ALL DIMENSIONS ARE APPROXIMATE AND SUBJECT TO MODIFICATION BY DESIGN ENGINEERING.	PROPRIETARY AND CONFIDENTIAL THIS INFORMATION CONTAINED IN THIS DRAWING IS THE SOLE PROPERTY OF ROAD RESCUE ANY REPRODUCTION IN PART OR AS A WHOLE WITHOUT THE WRITTEN PERMISSION OF ROAD RESCUE IS PROHIBITED.
	HEIGHT	WIDTH	DEPTH		HEIGHT	WIDTH	DEPTH		
J	24.00	33.35	18.50						
K2	6.00	48.00	8.75						
L1	13.25	13.75	21.50						
L2	21.75	12.00	18.50						

**Road Rescue** 2737 N. FORSYTH ROAD  
WINTER PARK, FL 32792

## LEFT INTERIOR DETAIL

BID NUMBER

www.roadrescue.com PHONE 800-932-7077 FAX 800-513-2688

DRAWN BY SG	DATE 06/01/17	REVISION 1	REVISION 2	REVISION 3	SCALE	SHEET 5 / 9
----------------	------------------	------------	------------	------------	-------	-------------

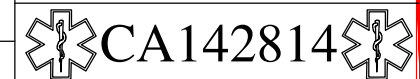

NOTE: THIS DRAWING IS SUBJECT TO CHANGE PENDING ROAD RESCUE PRODUCTION ENGINEERING APPROVAL. © ROAD RESCUE ALL RIGHTS RESERVED.



# AUSTIN TRAVIS COUNTY EMS D-4500 METROMEDIC

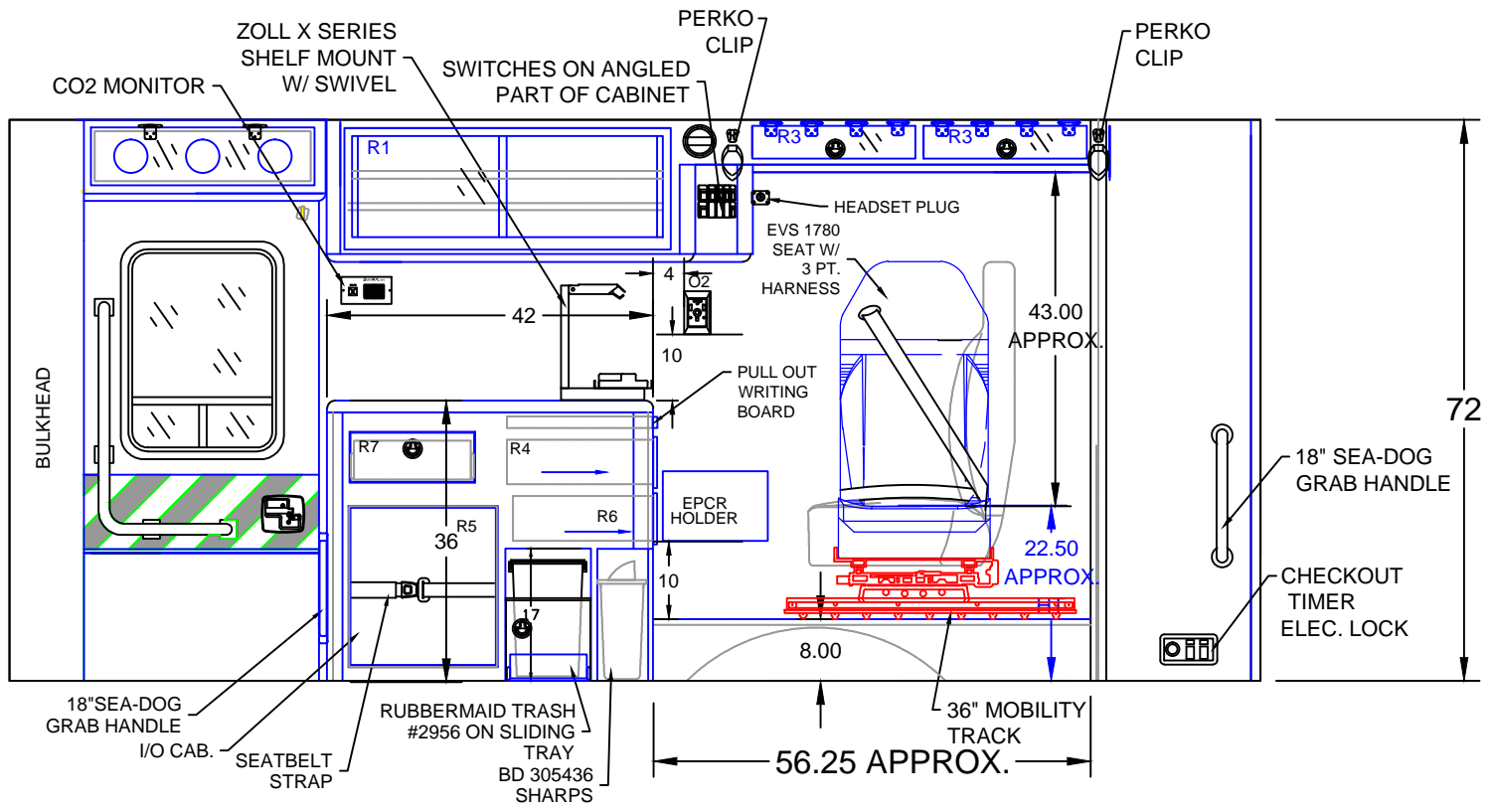

DOOR NO.	CABINET DIMENSIONS			DOOR NO.	CABINET DIMENSIONS		
	HEIGHT	WIDTH	DEPTH		HEIGHT	WIDTH	DEPTH
R1	15.50	42.00	12.00	R4/R7	5.00	15.00	18.00
R2/R3	4.50	21.00	8.75	R6	5.00	15.00	18.00
R5	20.00	19.00		EPCR	9.00	13.50	2.50
				TRASH	17.00	10.00	16.00

**NOTES:**

DETAILS ARE CONCEPTUAL ONLY. LAYOUT AND ALL DIMENSIONS ARE APPROXIMATE AND SUBJECT TO MODIFICATION BY DESIGN ENGINEERING.

PROPRIETARY AND CONFIDENTIAL  
THIS INFORMATION CONTAINED IN THIS DRAWING IS THE SOLE PROPERTY OF ROAD RESCUE ANY REPRODUCTION IN PART OR AS A WHOLE WITHOUT THE WRITTEN PERMISSION OF ROAD RESCUE IS PROHIBITED.

**Road Rescue**  
2737 N. FORSYTH ROAD  
WINTER PARK, FL 32792  
www.roadrescue.com PHONE 800-932-7077 FAX 800-513-2688

## RIGHT INTERIOR DETAIL

BID NUMBER  
**CA142814**

DRAWN BY SG	DATE 06/01/17	REVISION 1	REVISION 2	REVISION 3	SCALE	SHEET 6 / 9
----------------	------------------	------------	------------	------------	-------	-------------

NOTE: THIS DRAWING IS SUBJECT TO CHANGE PENDING ROAD RESCUE PRODUCTION ENGINEERING APPROVAL. © ROAD RESCUE ALL RIGHTS RESERVED.



# AUSTIN TRAVIS COUNTY EMS D-4500 METROMEDIC

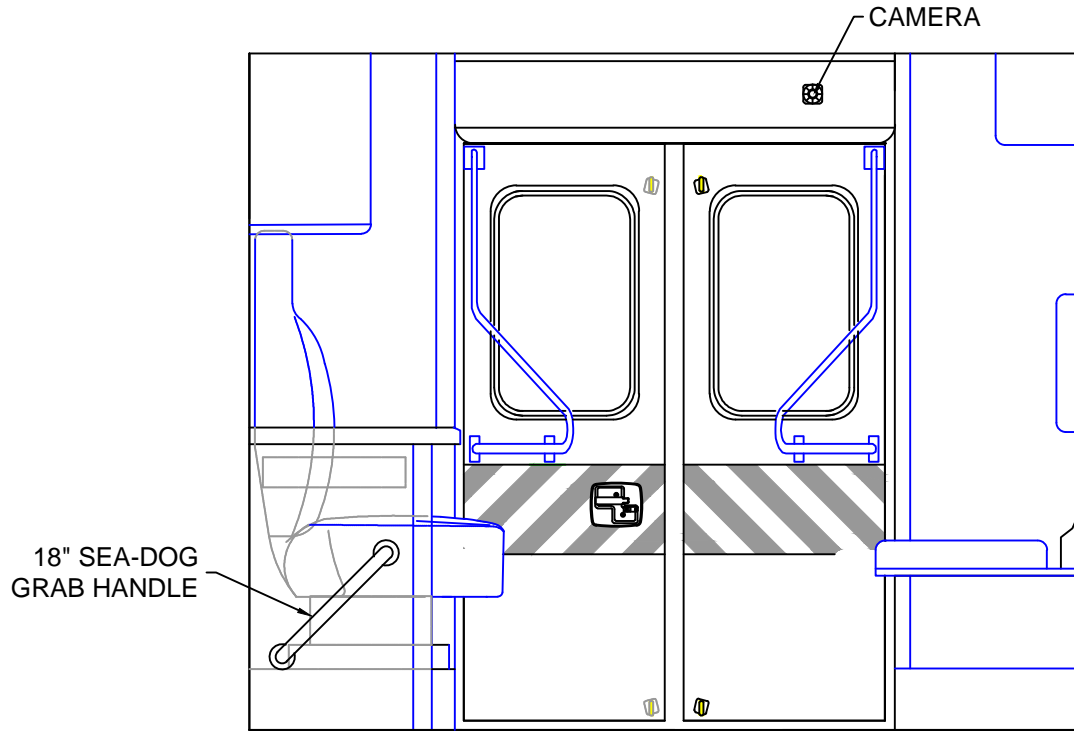

NOTES:

NOTES:

DETAILS ARE CONCEPTUAL ONLY.  
LAYOUT AND ALL DIMENSIONS ARE APPROXIMATE AND  
SUBJECT TO MODIFICATION BY DESIGN ENGINEERING.

PROPRIETARY AND  
CONFIDENTIAL  
THIS INFORMATION  
CONTAINED IN THIS  
DRAWING IS THE SOLE  
PROPERTY OF ROAD  
RESCUE ANY  
REPRODUCTION IN PART  
OR AS A WHOLE  
WITHOUT THE WRITTEN  
PERMISSION OF ROAD  
RESCUE IS PROHIBITED.

**Road Rescue** 2737 N. FORSYTH ROAD  
WINTER PARK, FL 32792

www.roadrescue.com PHONE 800-932-7077 FAX 800-513-2688

## REAR INTERIOR DETAIL

BID NUMBER

DRAWN BY  
SG

DATE  
06/01/17

REVISION 1

REVISION 2

REVISION 3

SCALE

SHEET 7 / 9

 CA142814 

NOTE: THIS DRAWING IS SUBJECT TO CHANGE PENDING ROAD RESCUE PRODUCTION ENGINEERING APPROVAL. © ROAD RESCUE ALL RIGHTS RESERVED.



# AUSTIN TRAVIS COUNTY EMS D-4500 METROMEDIC

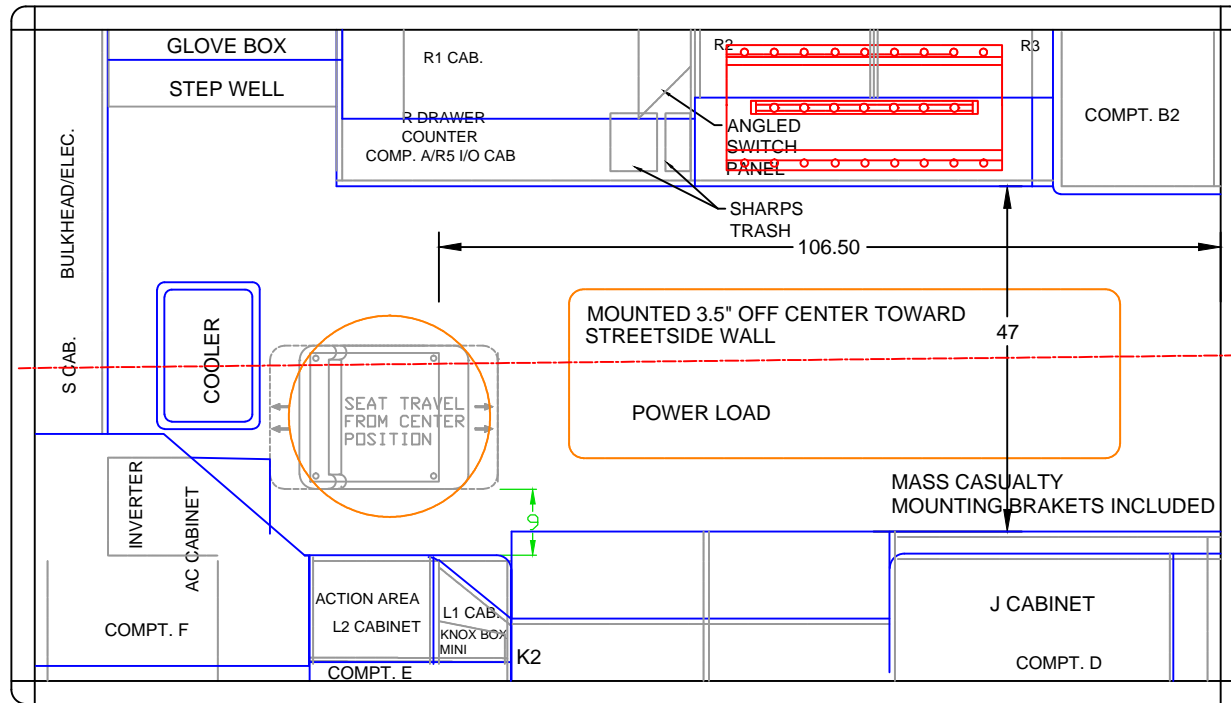

NOTES:

NOTES:

DETAILS ARE CONCEPTUAL ONLY.  
LAYOUT AND ALL DIMENSIONS ARE APPROXIMATE AND  
SUBJECT TO MODIFICATION BY DESIGN ENGINEERING.

PROPRIETARY AND  
CONFIDENTIAL  
THIS INFORMATION  
CONTAINED IN THIS  
DRAWING IS THE SOLE  
PROPERTY OF ROAD  
RESCUE ANY  
REPRODUCTION IN PART  
OR AS A WHOLE  
WITHOUT THE WRITTEN  
PERMISSION OF ROAD  
RESCUE IS PROHIBITED.

**Road Rescue** 2737 N. FORSYTH ROAD  
WINTER PARK, FL 32792

www.roadrescue.com PHONE 800-932-7077 FAX 800-513-2688

## OVERHEAD FLOOR DETAIL

BID NUMBER

DRAWN BY  
SG

DATE  
06/01/17

REVISION 1

REVISION 2

REVISION 3

SCALE

SHEET 8 / 9



NOTE: THIS DRAWING IS SUBJECT TO CHANGE PENDING ROAD RESCUE PRODUCTION ENGINEERING APPROVAL. © ROAD RESCUE ALL RIGHTS RESERVED.





# AUSTIN TRAVIS COUNTY EMS D-4500 METROMEDIC

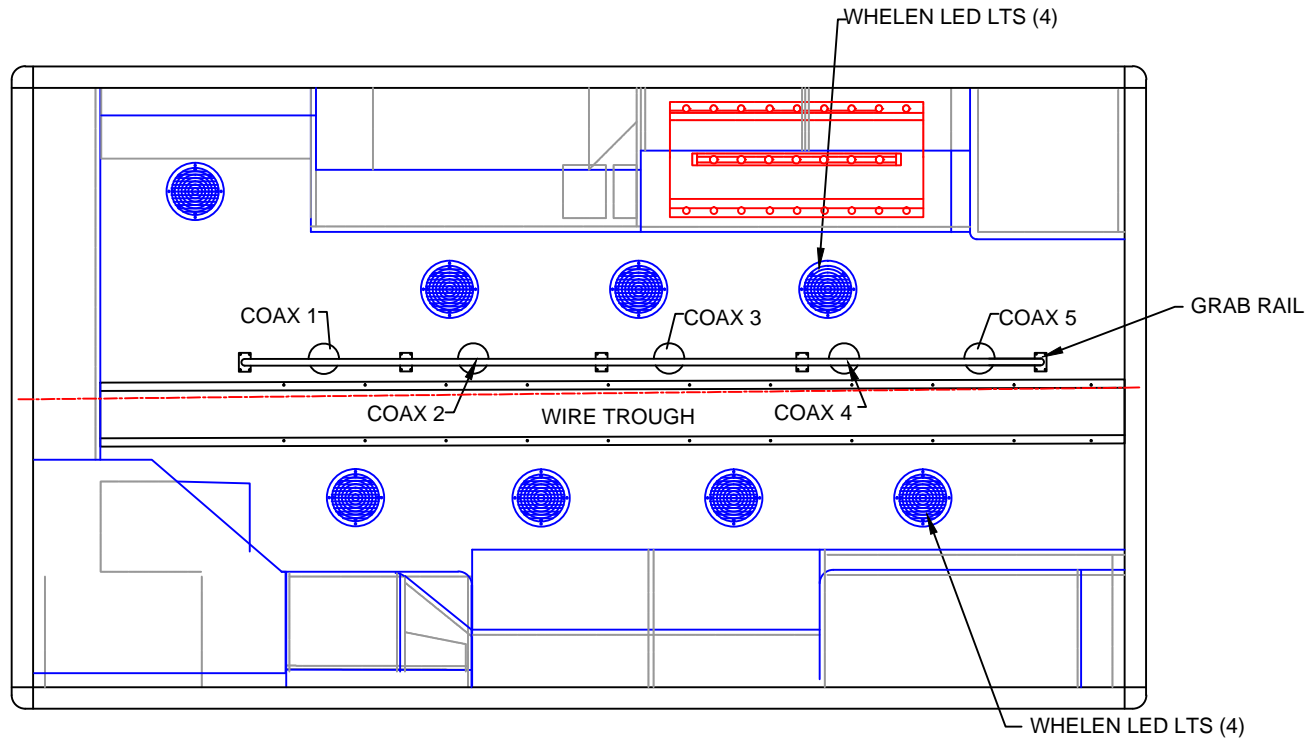

NOTES:

NOTES:

DETAILS ARE CONCEPTUAL ONLY.  
LAYOUT AND ALL DIMENSIONS ARE APPROXIMATE AND  
SUBJECT TO MODIFICATION BY DESIGN ENGINEERING.

PROPRIETARY AND  
CONFIDENTIAL  
THIS INFORMATION  
CONTAINED IN THIS  
DRAWING IS THE SOLE  
PROPERTY OF ROAD  
RESCUE ANY  
REPRODUCTION IN PART  
OR AS A WHOLE  
WITHOUT THE WRITTEN  
PERMISSION OF ROAD  
RESCUE IS PROHIBITED.

**Road Rescue** 2737 N. FORSYTH ROAD  
WINTER PARK, FL 32792

www.roadrescue.com PHONE 800-932-7077 FAX 800-513-2688

## OVERHEAD CEILING DETAIL

BID NUMBER

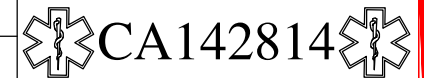

DRAWN BY  
SG

DATE  
06/01/17

REVISION 1

REVISION 2

REVISION 3

SCALE

SHEET 9 / 9

NOTE: THIS DRAWING IS SUBJECT TO CHANGE PENDING ROAD RESCUE PRODUCTION ENGINEERING APPROVAL. © ROAD RESCUE ALL RIGHTS RESERVED.